



@concept2uk | facebook.com/concept2



MARCH

Olympic Race Distance (2000m)

This is the standard race distance for most indoor competitions and the fastest time ever recorded was;

Rob Waddell
New Zealand
5:36.6

Entries close (11pm)
1ST APRIL 2013

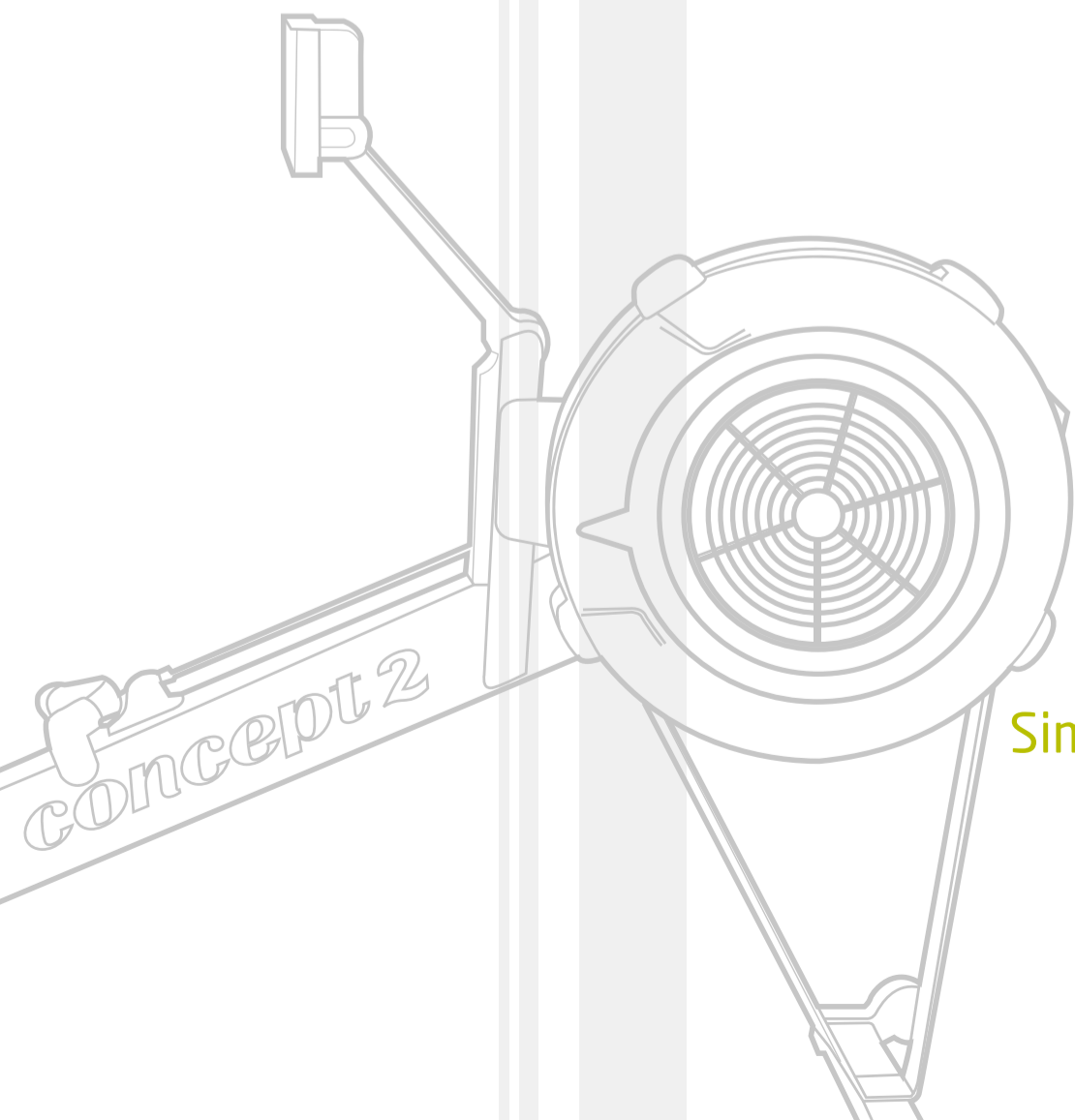

Want to know more?

Simply visit concept2.co.uk/challengeseries

